

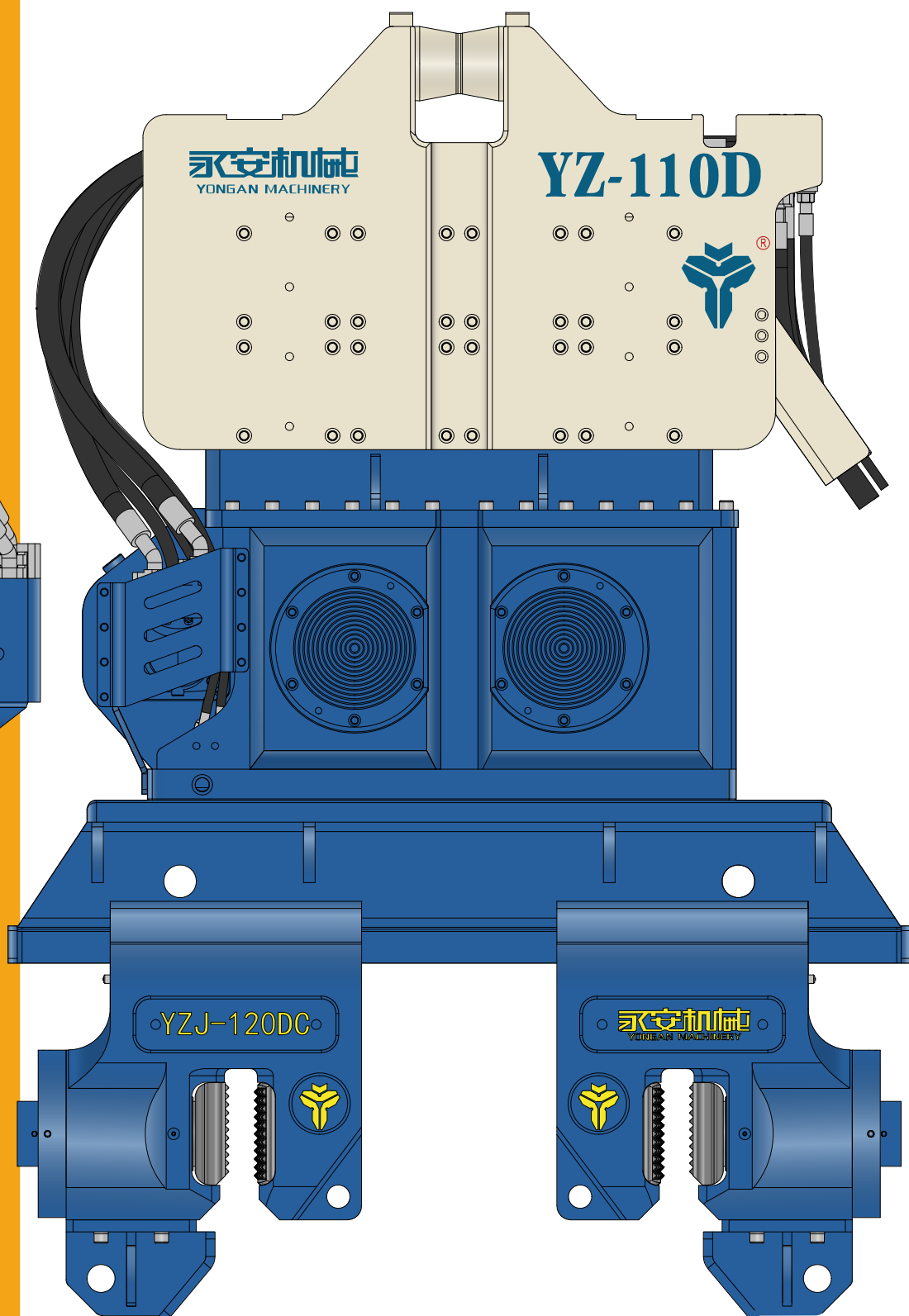

Piling hammer
Manufacturer

YZ-110D

Hydraulic
Vibratory
Pile Driving &
Extracting Hammer

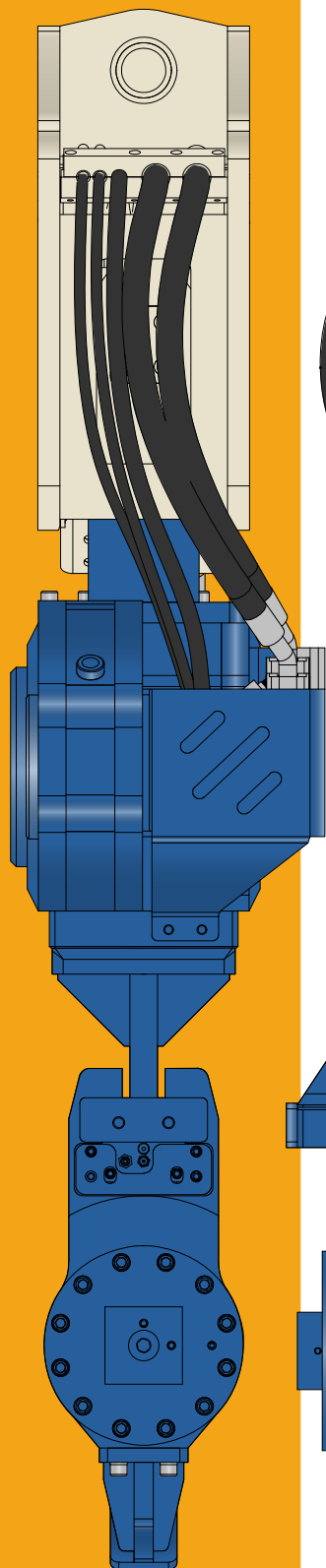

Features & Benefits



Piling hammer
Manufacturer

perfect designed suppressor house with low weight provide more driving and extracting capability

Heavy duty lifting pin for easy rigging and maximum safety

Maximum oil sealing capability with perfect machinery designing

Deep bored top steel plate let hydraulic oil go through it, provide more heat dissipation way

High-precision CNC machined gear box, make eccentric gear block run more smoothly

Yongan vibro hammer can be shipped fully assembled on one truck or container

FAG X-life giant spherical bearings provide 5 times durability than those found on other vibro hammer

Eccentrics block filled with "Heavy Metal" provide extra driving & extracting capability

One piece eccentric/gear part design eliminates bolts, keyways, splines and pins etc. other parts

Clamping jaw block make from Super hard alloy material providing extreme long working life.

Forged hydraulic clamping body provide perfect clamping performance for piles

Bosch Rexroth hydraulic motor, The best motor available on the market for vibro hammer. The hydraulic motor adopts embedded mechanical design mounted on the vibrating hammer body. Avoid damage due to lifting movement Perfectly.

SCHAEFFLE



FAG

X-life

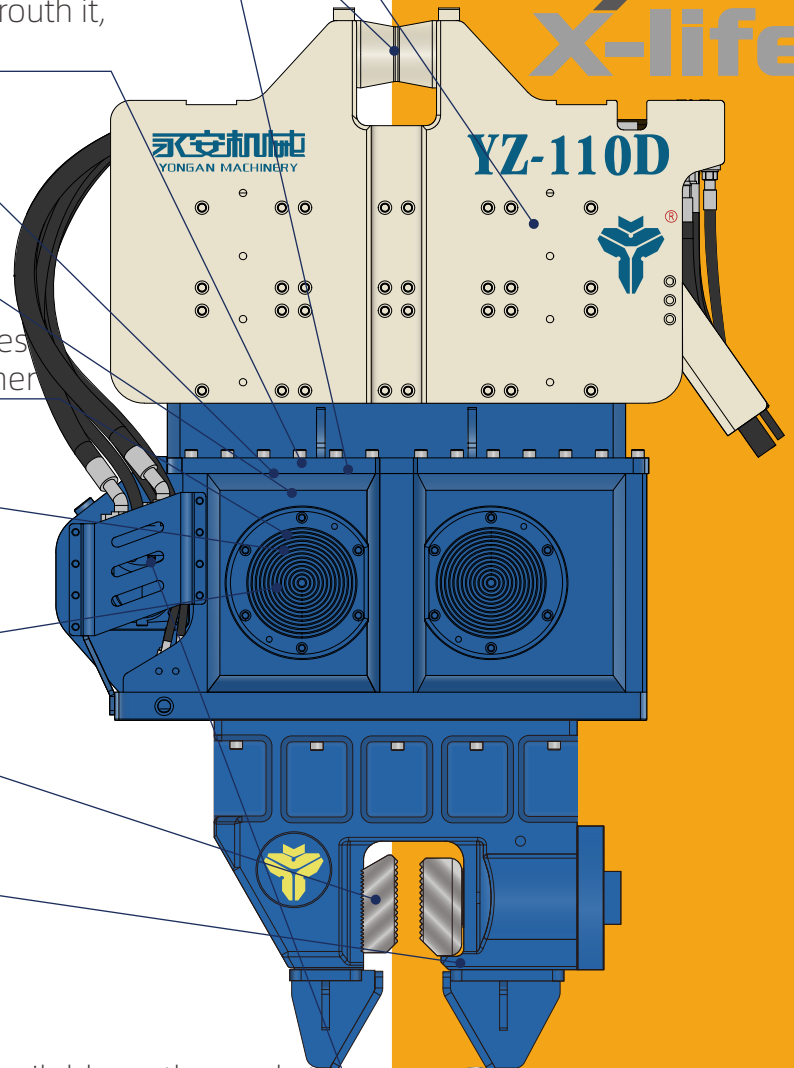

 **BOSCH**

rexroth

 **manuli**
HYDRAULICS



Piling hammer
Manufacturer

Technical Parameters

YZ-110D Hydraulic Vibro Hammer

Eccentric Moment:	32	kgm
Max. Frequency:	1800	rpm
Rated Centrifugal Force:	1140	kN
Max. Centrifugal Force:	1480	kN
Max. Line Pull Force:	600	kN
Max. Amplitude:	33	mm
Max. Oil Flow:	480	L/min

Amplitude Equation:

$$A = \frac{2 \times Mt}{Mv}$$

Mt = Eccentric Moment (kgm)
 Mv = Total Vibrating Weight (kg)
 A = Amplitude (mm)

About Vibrating weight Mv :

The vibrating weight is the sum of all the weights of the vibrating mass.

Note: Calculate pipe pile weight using the following formula:

$$(O-T) * T * 0.0246615 * H$$

O = Outside Diameter of pipe piles

T = Wall Thickness of Pipe Piles

H = Height of the pipe piles



永安机械
YONGAN MACHINERY



Piling hammer
Manufacturer

Size & Weight

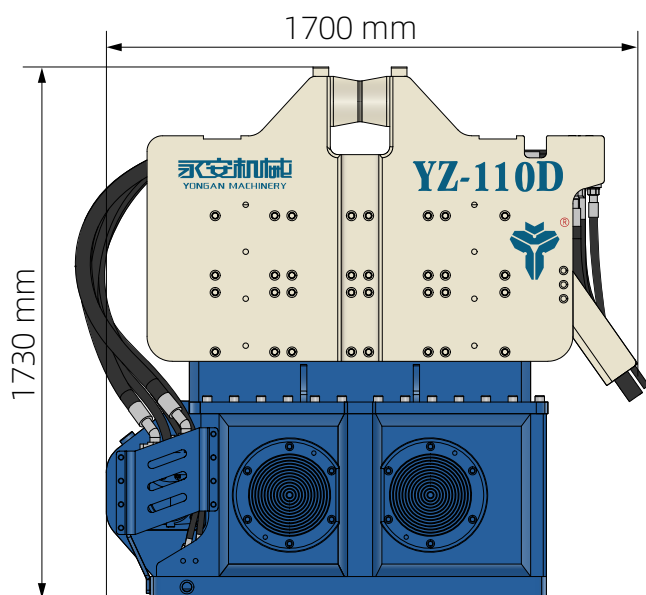

3300 kgs

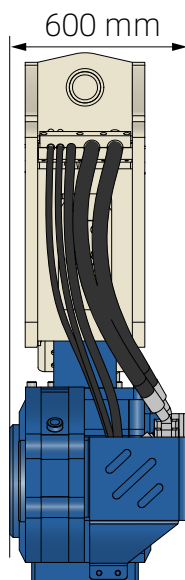

Double hydraulic clamp for
Big size of pipe piles

Single hydraulic clamp for
sheet pile and
small size of pipe piles

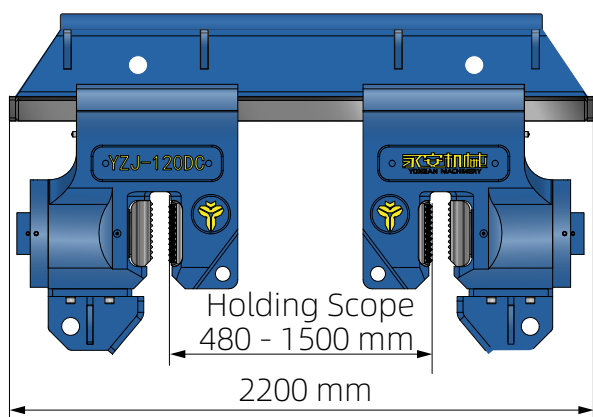

2150 kgs

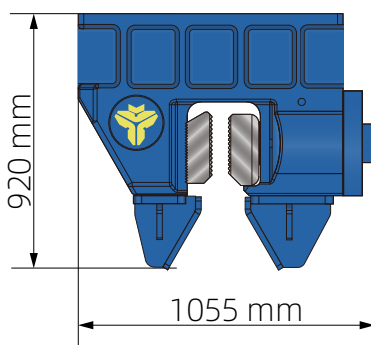

950 kgs

Clamping Force: 1200 kN

Working Pressure: 320 bar

YZ-110D Hydraulic Vibro Hammer



Piling hammer
Manufacturer

Piling Applications

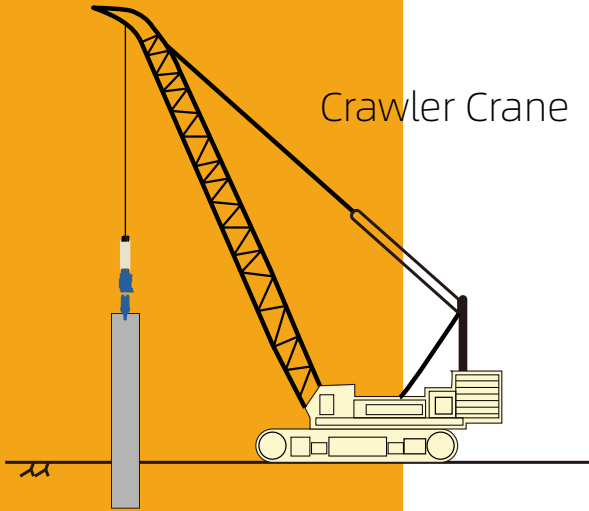

Crawler Crane

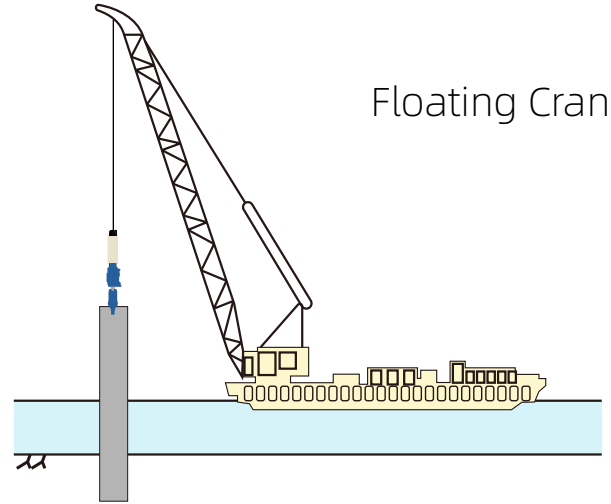

Floating Crane

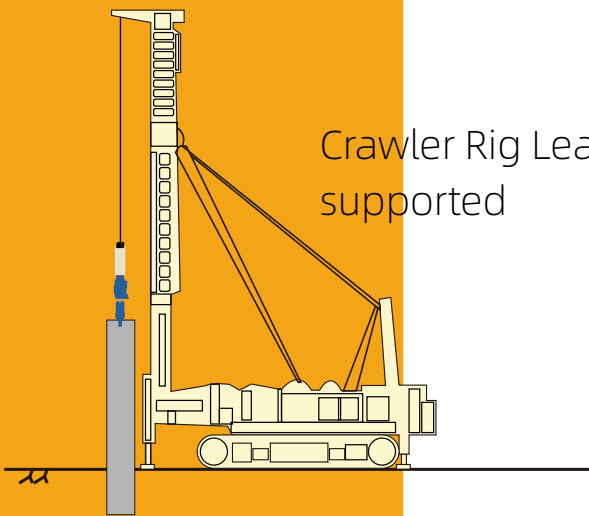

Crawler Rig Lead supported

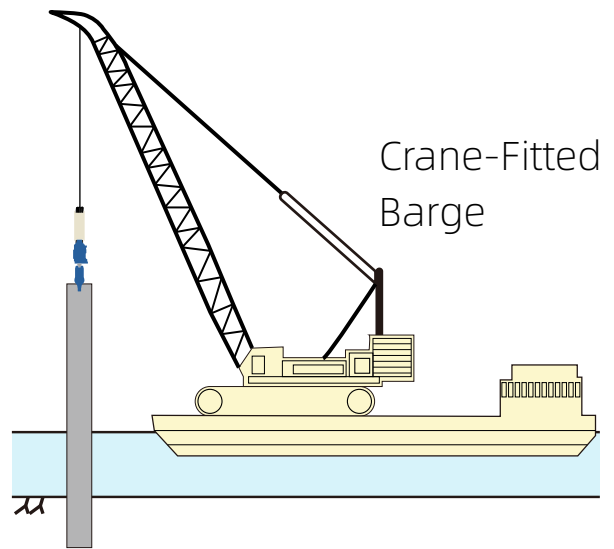

Crane-Fitted Barge

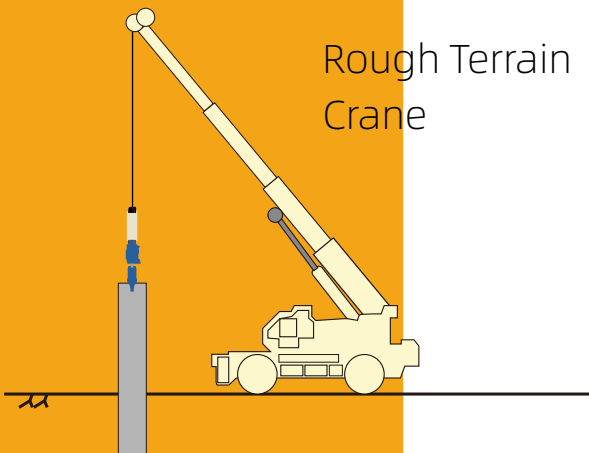

Rough Terrain Crane

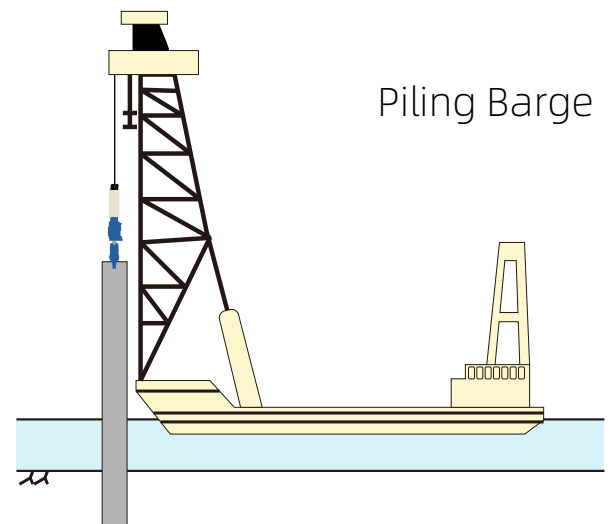

Piling Barge



永安机械
YONGAN MACHINERY

Hydraulic Power Pack



Piling hammer
Manufacturer

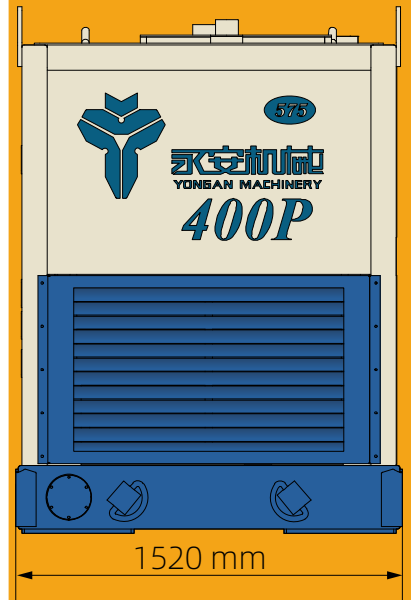
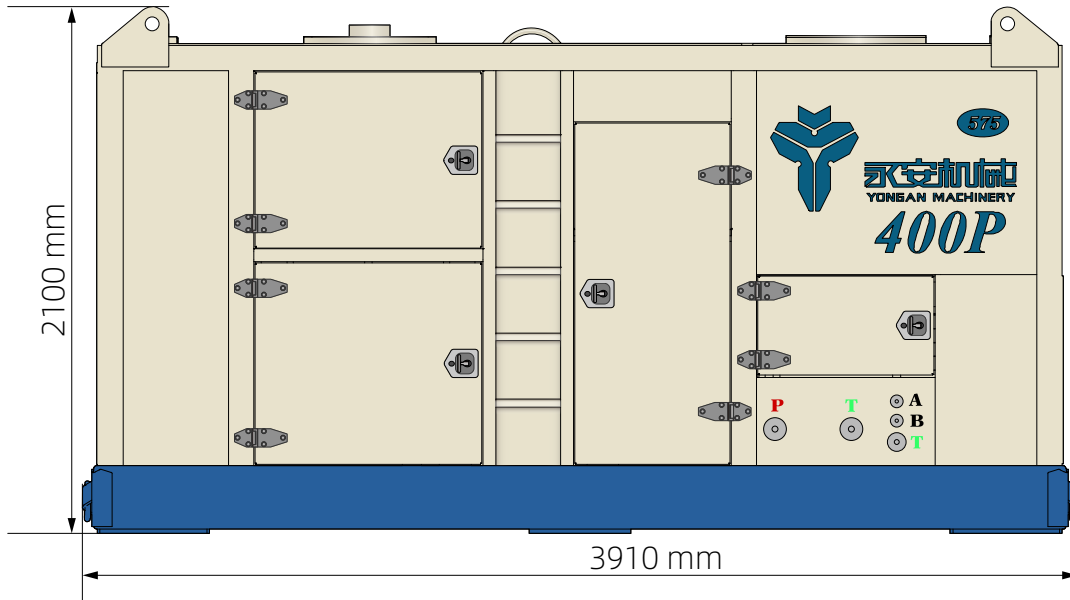

- ◆ Engine Type: Cummins QSM11
- ◆ Working Pressure: 280 bar
- ◆ Hydraulic Oil Tank Volume: 1400 L
- ◆ Max. Power: 298 Kw / 400 HP
- ◆ Max. Oil Flow: 430 L/min
- ◆ Weight: 6000 KGS
- ◆ Max. Frequency: 2100 rpm
- ◆ Diesel Tank Volume: 500 L

Feature:

Economical and durable

- Uses a high-performance Rexroth hydraulic plunger pump that pursues economy and durability

Quietness and portability

- Compact and lightweight body that takes into consideration quietness and portability by making full use of soundproofing technology.

Environmental

- Equipped with a third exhaust gas countermeasure engine optional, or take a electric motor instead of diesel engine.
- Uses biodegradable fats and oils as grease.

Functional

Yongan hydraulic power pack both can support for hydraulic vibro hammer and hydraulic impact hammer.





Piling hammer
Manufacturer

Hydraulic Power Pack

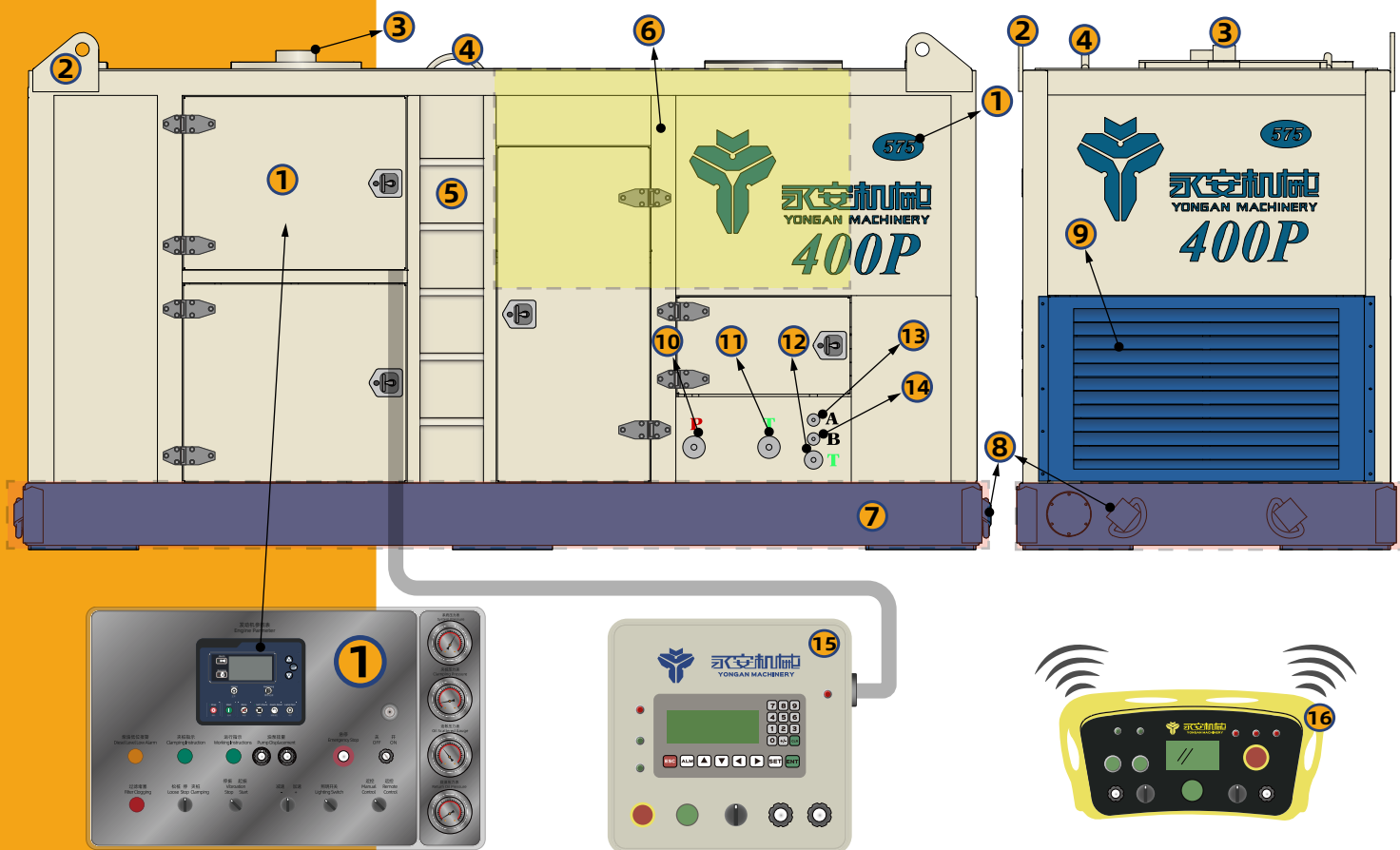

1. Local Control Panel & Instrument
2. Link for 4-point pickup
3. Diesel engine exhaust
4. hand holder
5. ladder
6. Hydraulic Oil Tank
7. Diesel Tank
8. Below lifting hooks
9. oil heat exchange & cooler compartment
10. pressure hydraulic oil quick coupling port
11. return hydraulic oil quick coupling port
12. case drain coupling port
13. pressure hydraulic oil quick coupling port for clamp
14. return hydraulic oil quick coupling port for clamp
15. cable remote control panel box
16. wireless remote control panel box

Contact us

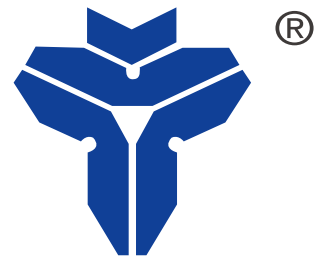

Piling hammer
Manufacturer

Zhejiang Yongan Construction Machinery Co.,Ltd
📍 : 1458 Binhai 1st Road, Binhai Industrial Zone
Wenzhou, China 325025

Fujian New Yongan Machinery Co.,Ltd
📍 : Guanling Industrial Zone, Fuding city
Fujian Province, China

Zhejiang Yongan Construction Machinery Co.,Ltd Ruian Brance
📍 : No.88 Qing'ao, Haiyang Industrial zone, Tangxia town
Rui'an city, China

🌐 : <http://en.yonganjx.cn>

☎ : 86-13758772918

✉ : tom@yonganjx.cn

📘 <https://www.facebook.com/YonganConstructionMachinery/>

🐦 <https://twitter.com/ZhejiangYongan/>

📺 <https://www.youtube.com/channel/UCnmaeeXsNNGuE5swNqH-rVw/>

📷 https://www.instagram.com/yongan_machinery/

📌 <https://www.pinterest.com/yonganconstructionmachinery/>

